

*ProCam  
Metering Pumps*



# ProCam Diaphragm Metering

## Economical and reliable

These pumps with mechanically actuated dual diaphragms bring the advantages and security of the diaphragm design to applications with operating pressure up to 20 bar and flow rates up to 3.000 l/h at an economical price.



DS 50 with stainless steel pumphead and electric flow rate control

## Applications

- **Protecting the metered liquid** against contamination from pump gasket particles and lubricants, e.g. for potable water handling and treatment.
- Pumping hazardous or toxic liquids, where a **leakproof pump** is essential.
- An economical solution when **high operating security** and reliability is mandatory.

## Advantages

### Excellent operating security

- **Hermetically sealed pump**  
Metering pumphead with mechanically actuated PTFE double-diaphragm
- **Diaphragm condition monitoring system** signals broken diaphragms by either hose nipple, pressure gauge, or pressure switch

### Economical pumping of hazardous liquids

- **Excellent chemical resistance** due to high-grade PTFE double-diaphragm
- **Two years warranty** on the diaphragm due to special qualities of the diaphragm material

## Materials

### Pump head and valve housing

- Stainless steel construction
- Plastic construction

### Gear box

- Rugged cast iron housing with metallic internals

## Options & Features

### Flow rate control

- Manual (standard)
- Electric motor (option)
- Electric motor with integrated control electronics (option)

### Modular design

- **Multiple pump combinations** are available, with up to 6 pumpheads and different combinations of gear modules (types 15-500)

Standard double-diaphragm

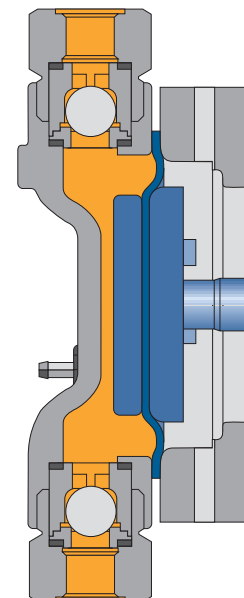
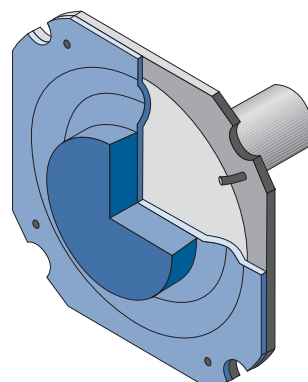

# Pumps

## Flow rate and pressure for individual pumpheads

Pump type		max. flowrate* (l/h)					max. pressure bar	connections nominal size DN***
		50	72	100	144	200		
DS / DP	15	5	7.5	10	15	20 **	10	
DS / DP	50	17,5	25	35	50	10	10	
DS / DP	100	35	50	70	100	4	15	
DS / DP	200	70	100	140	200	12 **	15	
DS / DP	500	175	250	350	500	5	25	
DS / DP	850	300	430	600	860	3	25	
DS / DP	3000	1040	1500	2080	3000	5	50	

\* Values at 100% volumetric efficiency.

\*\* Pressure for pump with plastic pumphead is limited to 10 bar

\*\*\* Various types of connections are available

**Example:** DS 50 = Pump with *stainless steel* pumphead  
DP 50 = Pump with *plastic* pumphead

## Dimensions and gear data

### Gear type

Integrated worm drive

### Lubrication

Splash lubrication

### Drive motor

Electric motor according  
to customer requirements

- Fixed speed
- Variable speed
- Explosion-proof equipment

DS / DP 15 - DS / DP 50 - DS / DP 100  
DS / DP 200 - DS / DP 500

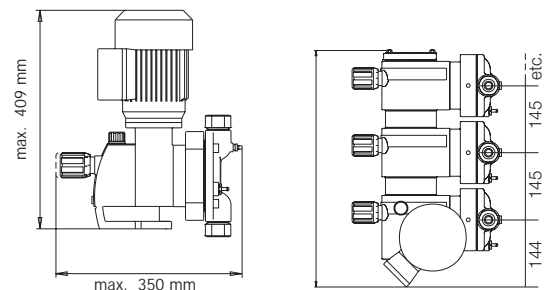

Figures for width are max. values

2 DS / 2 DP 850 - 2 DS / 2 DP 3000

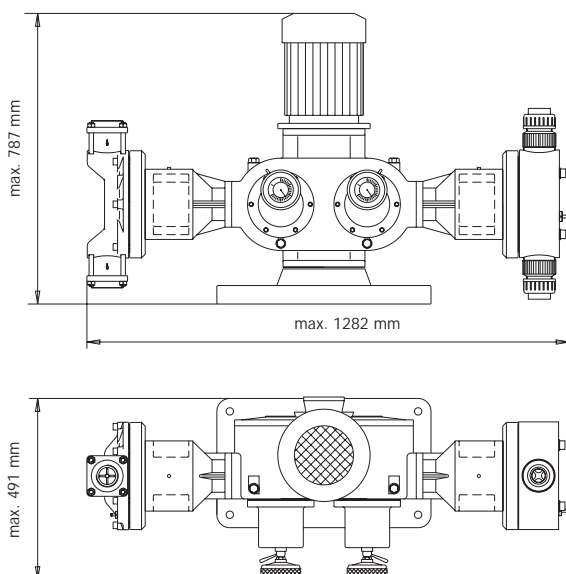

DS / DP 850 - DS / DP 3000

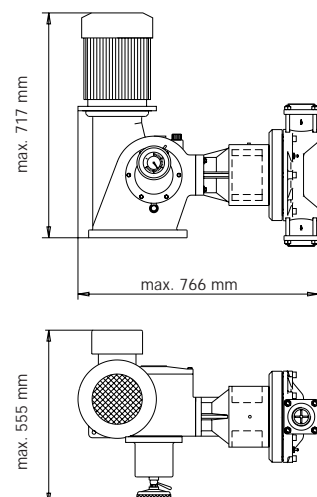

# ProCam Plunger Metering Pumps

## Economical and powerful

The ProCam plunger metering pumps are ideal for applications with operating pressures up to 80 bar, especially for the economic metering of nonhazardous liquids with flow rates from 0.16 to 60.5 l/h. Robust gear technology with proven cam and spring design for long operating life.



Plunger metering pump with stainless steel pumphead and manual flow rate control.

## Applications

- *Economic metering* of non-hazardous fluids
- *Operating pressure* up to 80 bar
- *Flow rates* from of 0.16 to 60.5 l/h

## Advantages

### *Robust gear technology*

- *Proven cam and spring design* for long operating life
- Linear stroke length adjustment *manual* and by *electric servomotor*

- *High operational security*, even under difficult conditions

- Pump head and valves in *stainless steel*

### *Flexible, modular design*

- *Multiple pump* combinations are available, with up to 6 pumpheads and different combinations of gear modules

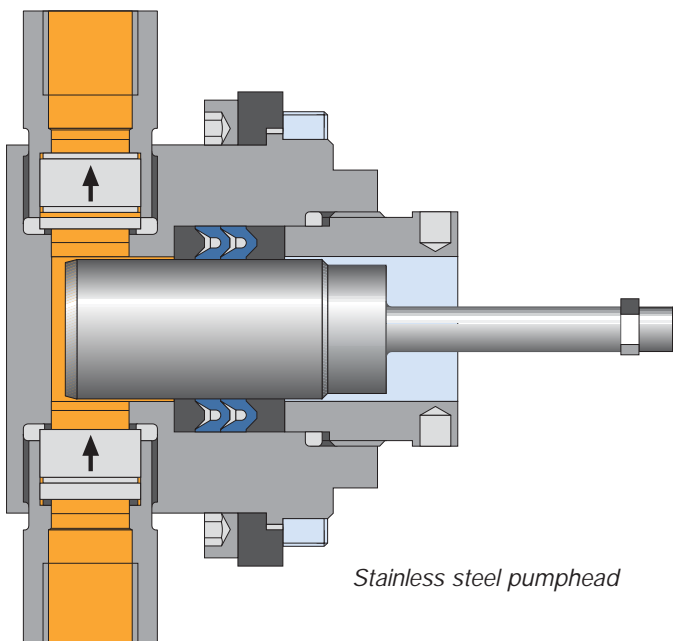

## Technical data

Type	max. flow rate* (l/h)				max. pressure (bar)*	Connections F	Material in contact with metered liquid
	Stroke frequency min <sup>-1</sup>	50	72	100			
<b>PS 3</b>	0.16	0.23	0.32	0.46			
<b>PS 5</b>	0.40	0.57	0.80	1.15	80	G 1/4 female	1.4571
<b>PS 8</b>	1.05	1.51	2.10	3.00			
<b>PS 10</b>	3.20	4.80	6.40	9.60	80		
<b>PS 16</b>	8.60	12.30	17.20	24.70	80	G 3/8 female	1.4571 / 1.4581
<b>PS 25</b>	21.00	30.20	42.00	60.50	32		

\* In the case of multiple pumps with 4-6 pump heads the maximum pressure is 50% of the value given in the table.

**Type PS 3 to PS 8**

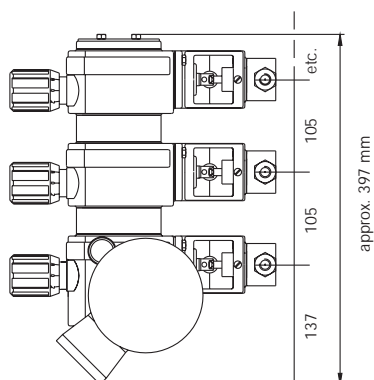
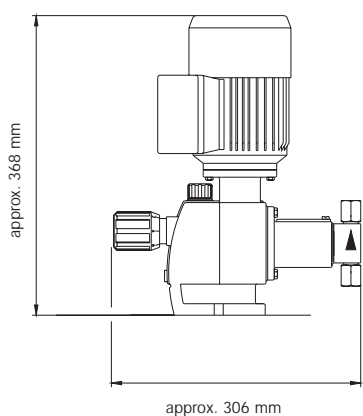

**Type PS 10 to PS 25**

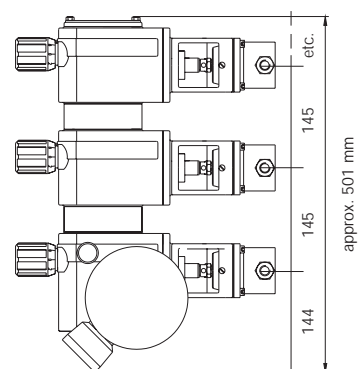
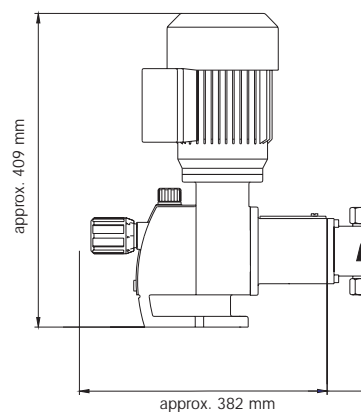

## Operating conditions

Ambient temperature	0°C to 40°C
Temperature of metered fluid	0°C to 80°C

## Drive motor

Standard	230/400 V; 50/60 Hz; IP 55; ISO KL. F
PS 3, PS 5, PS 8:	0,18 kW; 1400 rpm and 2800 rpm
PS 10, PS 16, PS 25:	0,37 kW; 1400 rpm or 0,55 kW, 2800 rpm

(Other motors on request)

# ProCam Compact Metering Station

This compact mixing and preparation unit, combined with a ProCam pump, offers a complete solution for preparing and metering chemical solutions.

## Applications

- Chemical industry, e.g. metering of additives and inhibitors
- Water preparation and treatment plants
- Clean-In-Place installations in the food and beverage industries
- Electroplating and surface treatment processes
- Preparation of fertilizer solutions



*ProCam - Compact metering station*

## Adaptable to individual requirements

- Tank sizes from 60 to 500 litres or on request
- Standard equipment includes suction pipe, inlet valve, manual stirrer and stable mounting plate for pumps
- Vessel is calibrated in litres and can be fitted with 1 or 2 contact level switches
- Cover is easily removed for quick filling and inspection

### Options

- Electric stirrer
- Optional choice of 1 or 2 contact level switches is available
- Pressure limiting valve with bypass to tank
- Drain valve for tank

## Solid construction

- A base plate for pumps weighing up to 50 kg provides a stable platform for the pump
- Temperature range up to 60°C
- Tanks are UV-resistant and can be used outdoors
- The polyethylene tank is resistant to most aggressive metered liquids
- Optional brackets are available to fix the container to the floor

## Installation

The standard specification, including suction pipe, inlet valve, hand operated stirrer and pump base plate, allows the ProCam to become operational at a glance in most installations. The level switches, pressure limiting valve and other options extend its applications to more demanding requirements and extend its operational security.

## Volume and dimensions

Tank	ØA	B	C1	C2	D
60 l	450	545	925	965	1/2"
100 l	470	730	110	1150	1/2"
200 l	610	875	1255	1295	1/2"
300 l	680	950	1330	1370	1"
500 l	830	1065	1445	1485	1"

Item	Description	Quantity	Material
1	ProCam metering pump	1	
2	Tank	1	PE
3	Base plate	1	PVC
4	Suction pipe	1	PVC
5	Foot valve	1	PVC
6	Manual stirrer	1	PVC
7	Option: Electric stirrer	1	
8	Option: Level switch	1	
9	Option: Pressure limiting valve	1	
10	Option: Drain valve	1	
11	Option: Foot bracket	4	PE

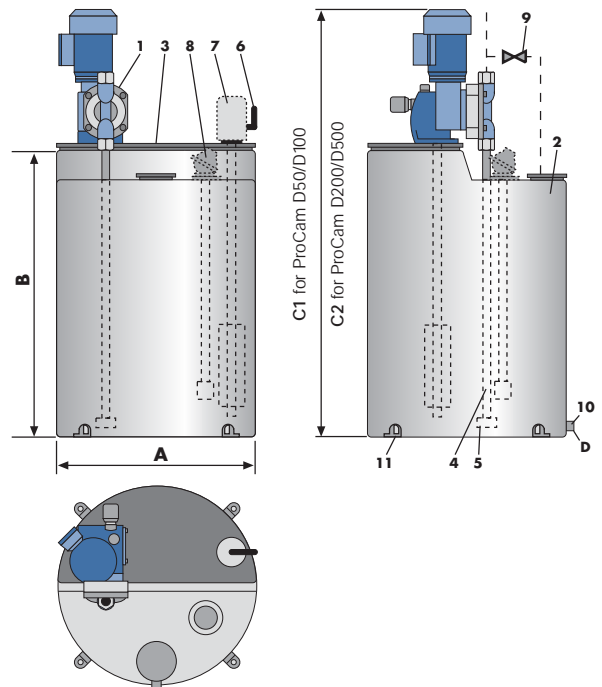

## Our Organisation

### Worldwide Support

Combining Bran+Luebbe, Lightnin, Plenty and Premier Mill has lead to a worldwide network of expertise in process equipment for industrial mixing and metering. With our own companies and representatives you will always find experienced support immediately available.

### Guarantee

All our products are built to last and we provide warranty periods that are appropriate for the specific industries where the equipment is located.

### After Sales and Service

Our dedicated direct service teams are readily available to support your process equipment at all times. Genuine spares and service solutions can be obtained from all our companies and ensure operating capacity of your valuable production equipment.

### Quality

We recognize that our customers demand a high quality product manufactured and serviced in a timely and efficient manner. Working within the process industry we are fully aware of the specific demands for quality standards and all our companies are ISO 9001 accredited.

## How to contact us



<http://www.bran-luebbe.de>



<http://www.lightnin-mixers.com>

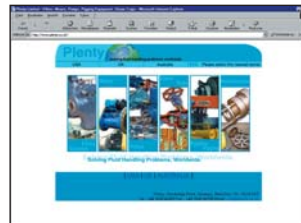

<http://www.plenty.co.uk>



<http://www.premiermill.com>

## Your local contact

